

4

3

2

1

REVISIONS			
REV	DESCRIPTION	DATE	APPROVED
A	INITIAL RELEASE	6/10/02	GAW
B	CHANGED .402 HOLE TO 3/8-24	6/25/02	GAW
C	CHANGED ID TO .125	1/29/03	GAW
D	ADDED DRILL $\varnothing$ .25 x 1.00 DP	3/04/03	GAW
E	CHANGED THREAD LENGTH	6/30/03	GAW
F	REDESIGNED	12/14/04	GAW
F1	CLARIFIED MATERIAL	6/1/09	GAW
G	CHANGED MATERIAL	1/8/19	GAW

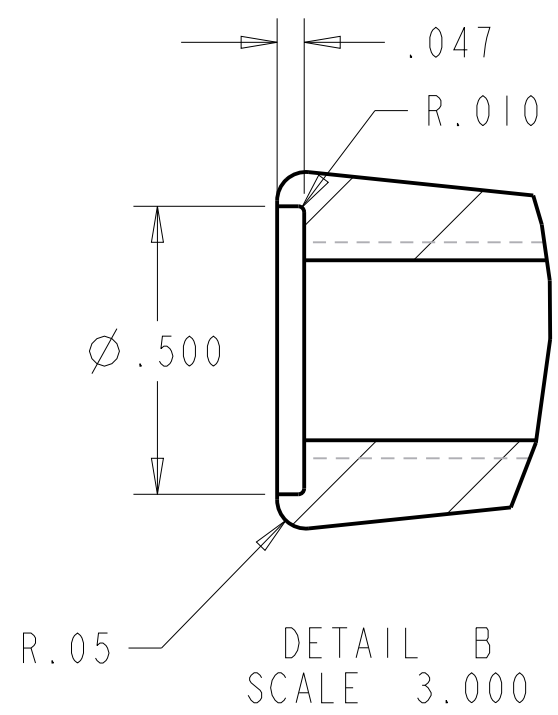
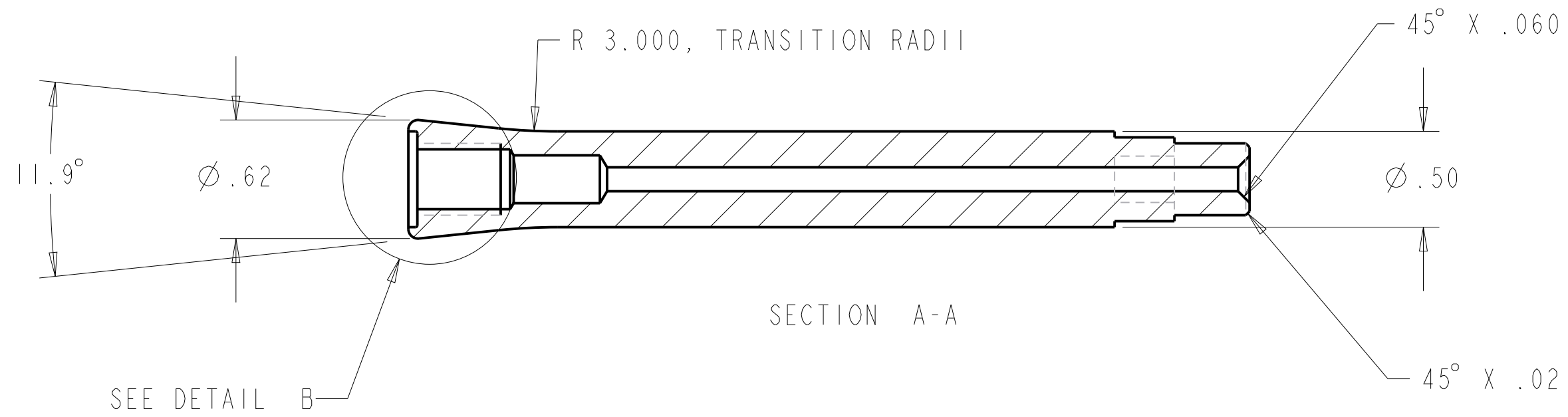
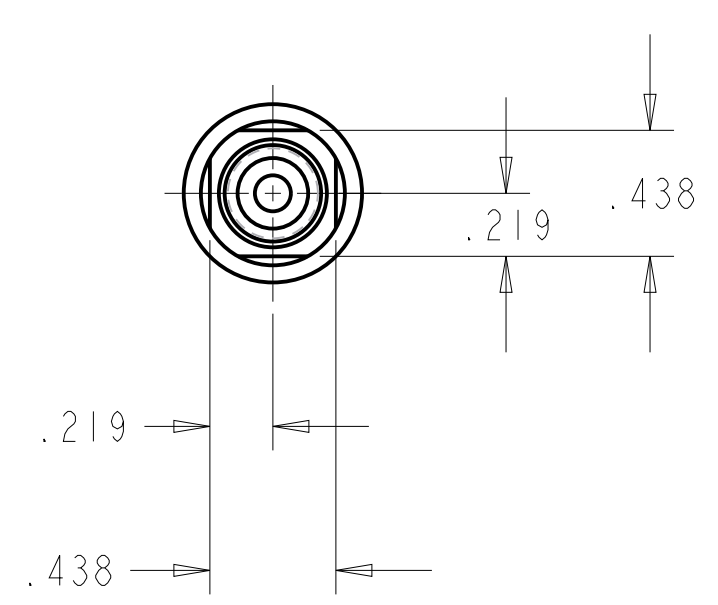
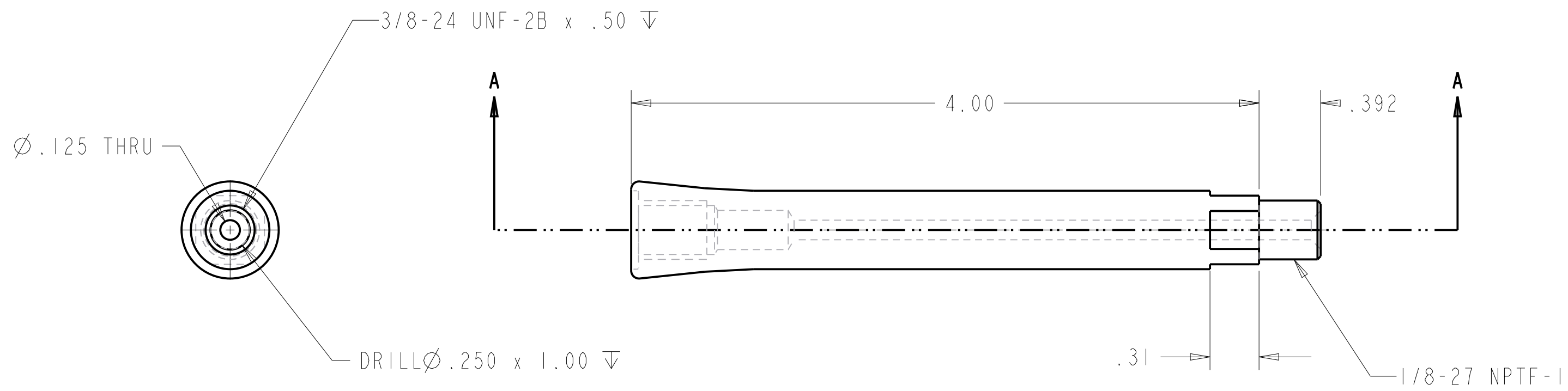

NEXT ASSY	EQCM USED ON
-----------	-----------------

MATERIAL  
KYNAR 740  
PVDF NATURAL

FINISH

DO NOT SCALE DRAWING

UNLESS OTHERWISE SPECIFIED,  
DIMENSIONS ARE IN INCHES.

TOLERANCES:  
.X ±  
.XX ± .01  
.XXX ± .005  
ANGLE ±

ENG BY/DATE  
G. WATERS  
DWN BY/DATE  
G. WATERS 15-Dec-04

**SRS** STANFORD RESEARCH SYSTEMS, INC.  
1290-D Reamwood Avenue, Sunnyvale CA 94089

DRAWING TITLE:  
PROBE, SIDE ARM, EQCM

SIZE <b>C</b>	PRO/E FILENAME:	SRS PART NO. 7-01386-721	REV G
SCALE: 1.50		SHEET: 1 OF 1	

4

3

2

1